

Reinhold Environmental Ltd.



2009 APC Round Table & Expo Presentation

July 12-14, 2009, in The Woodlands, TX

All presentations posted on this website are copyrighted by Reinhold Environmental, Ltd (RE). Any unauthorized downloading, attempts to modify or to incorporate into other presentations, link to other websites, or obtain copies for any other uses than the training of attendees to RE's Conferences is expressly prohibited, unless approved in writing by RE or the original presenter. RE does not assume any liability for the accuracy or contents of any materials contained in this library which were presented and/or created by persons who were not employees of RE.



Sargent & Lundy^{LLC}

Comparison of Dry FGD Technologies

Paul S. Farber

July 13, 2009

Overview

- Introduction
- Spray Dryer/Fabric Filter Overview
- Circulating Dry Scrubber/Fabric Filter Overview
- Design Emission Limits
- SO₂ Capture Capability
- Fuel Flexibility
- Load Flexibility
- Utilities Consumption
- Waste Production
- Summary

Selecting Between Similar Dry Scrubber Technologies

- Both Systems Lime Based
- Spray Dryer Based With Fabric Filter
- Circulating Dry Scrubber – Fluidized Bed Based With Fabric Filter

Spray Dryer/Fabric Filter Systems Have Been Operating On Coal Fired Power Plants Since The 1980's

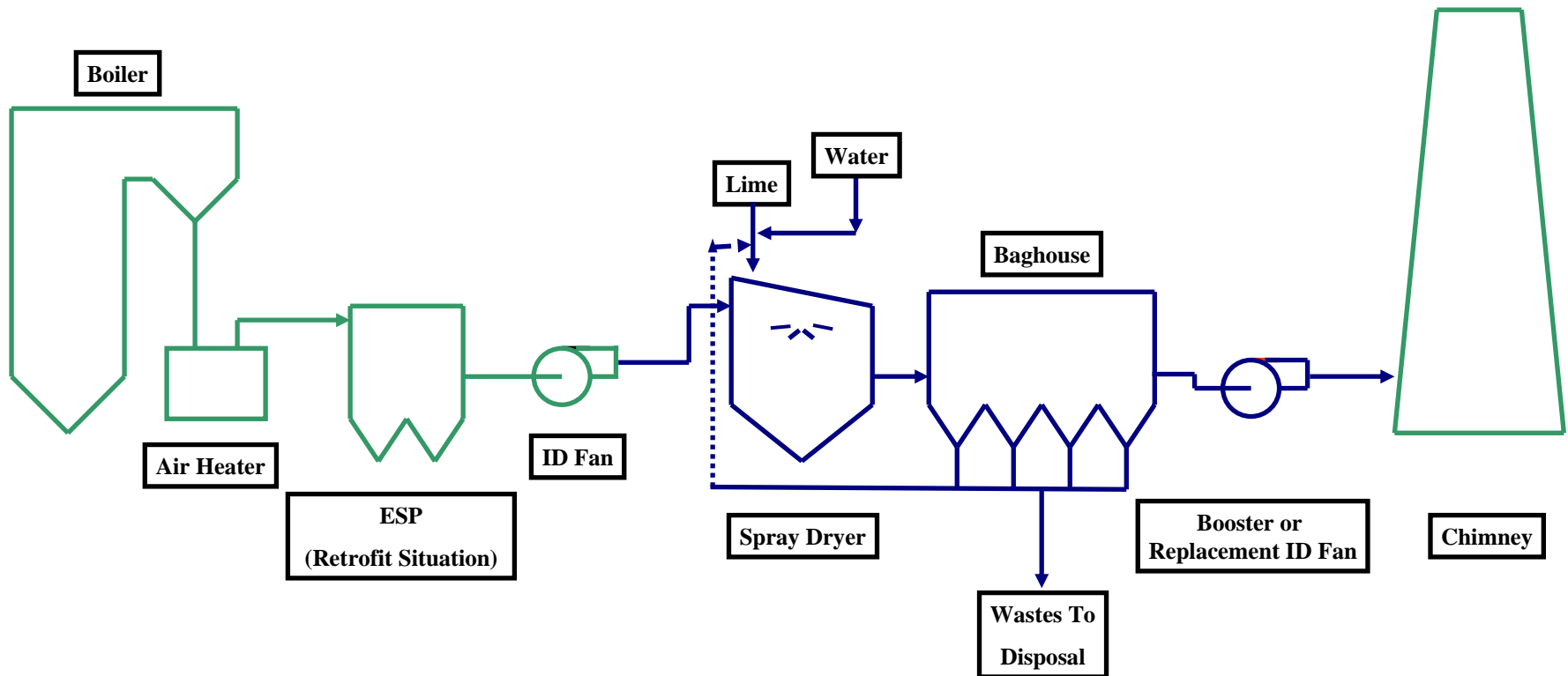

Photo Courtesy of Babcock & Wilcox

Spray Dryer Overview

- Approximately 50 Spray Dryer/Fabric Filter systems in operation on coal-fired Utilities in the US
- Largest single module ~300 – 400 MW
- Reagent
 - Lime slurry
- Slurry atomized in spray dryer
- Fabric filter separates particulates
- Byproduct of reaction
 - Natural oxidation – predominantly calcium sulfite
- Temperature of “clean” flue gas
 - Approach to adiabatic saturation temperature

Spray Dryer Absorber (SDA) Retrofit



Circulating Dry Scrubbers Are Now Being Installed On Coal-Fired Power Plants

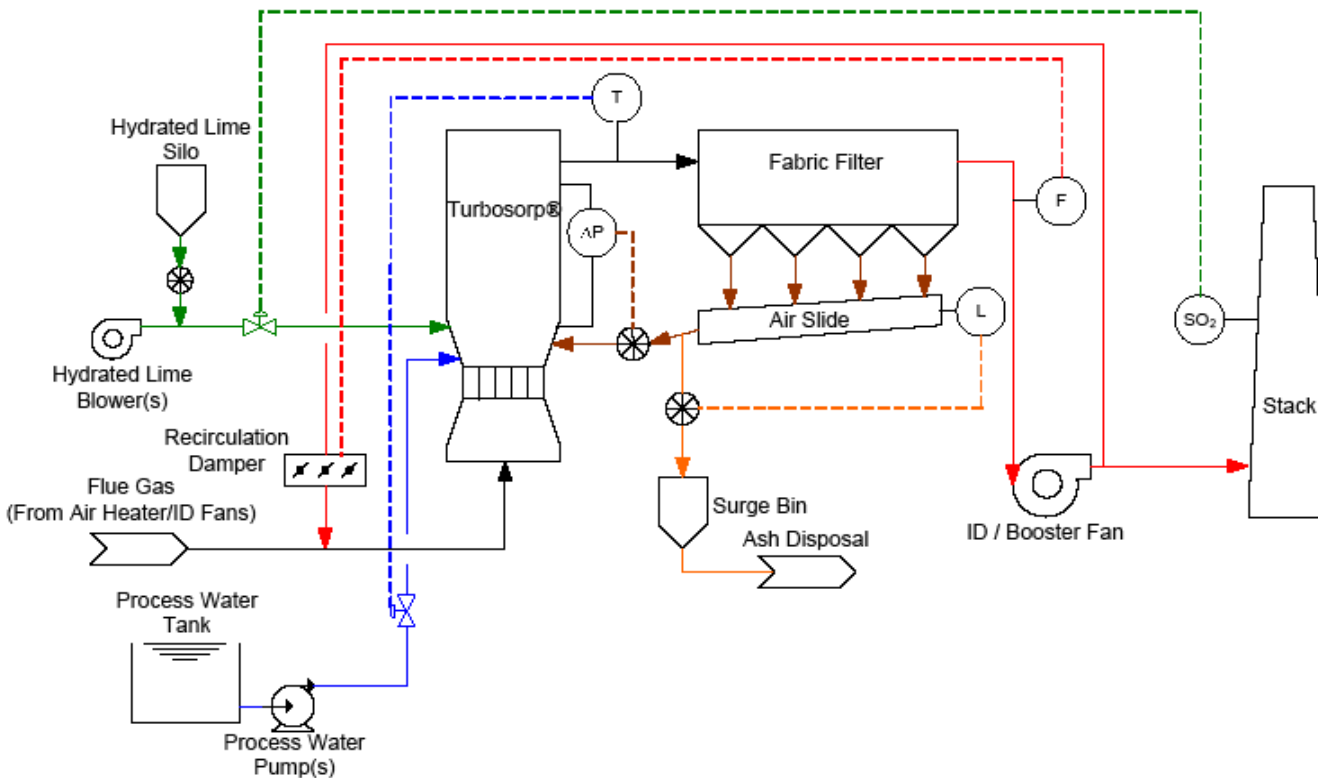

Photo Courtesy of Gainesville Regional Utilities

Circulating Dry Scrubber Overview

- Approximately 5 CDS/Fabric Filter systems in operation on coal-fired utilities in the US
- Largest single module (venturi) ~80 MW – may have several modules in a single vessel
- Reagent
 - Hydrated lime powder
- Hydrated lime and water injected separately into CDS
- Fabric filter separates particulates
- Byproduct of reaction
 - Natural oxidation – predominantly calcium sulfite
- Temperature of “clean” flue gas
 - Approach to gas saturation temperature

CDS Process Flow Diagram



Courtesy of Babcock Power

Major Items

- Reactor
- Process Water
- Lime Feed
- Fabric Filter
- Air Slide
- Booster Fan
- Flue Gas Dampers
- Ash System

Dry Scrubber Selection Criteria

- **Design Emission Limits**
- **SO₂ Capture Capability**
- **Fuel Flexibility**
- **Load Flexibility (i.e. Turndown)**
- **Utilities Consumption**
- **Waste Production**

Design Emission Limits

- Emission Limits for Criteria Air Pollutants
 - SO₂
 - VOC
 - PM
 - Hg
- Emissions Being Studied Under “Utility NESHAP” ICR
 - HCl, HF, HCN
 - Dioxins/Furans & Other Organics
 - Hg, Cr, Se, As, Co, Be, Cd, Pb, Mn, Ni
 - Radionuclides
- Both the SDA/FF and the CDS/FF should be able to reduce the emissions of present and future (possibly) regulated materials

SO₂ Capture Capability

- Spray Dryer/Fabric Filter
 - 0.05 lb/MMBtu
 - 95% Removal

- Circulating Dry Scrubber/Fabric Filter
 - 0.04 lb/MMBtu
 - 96% Removal

- The CDS/FF system has an advantage in SO₂ capture capability

Fuel Flexibility

- Both technologies limited by spray down ($T_{\text{inlet}} - T_{\text{outlet}}$) and by the approach to adiabatic saturation temperature
- Spray Dryer/Fabric Filter
 - Limited to ~2 – 3 lbs/MMBtu inlet SO_2 maximum
 - Limitations dependent upon removal required and inlet gas temperature
- Circulating Dry Scrubber/Fabric Filter
 - Limited to ~4 – 5 lbs/MMBtu inlet SO_2 maximum
 - Limitations dependent upon removal required and inlet gas temperature
- The CDS/FF system has an advantage in fuel flexibility

Load Flexibility

- Coal-fired utility boilers can operate at loads between 30% and 100% of MCR
- Spray Dryer/Fabric Filter systems can operate at turn-downs of ~3:1
 - Atomization of slurry into spray dryers is a function of load and inlet flue gas temperature
 - Longer residence times at low load improves drying
- Circulating Dry Scrubber/Fabric Filter systems can operate at turn-downs of ~2:1
 - The need to maintain a fluidized bed in the CDS sets the lower load/velocity in the reactor
 - Lower load operation is possible if a return flue gas duct is installed with dampers
- The Spray Dryer system has an advantage in load flexibility

Utilities Consumption

- Water consumption for both SDA/FF and CDS/FF systems are a function of the temperature approach and are approximately equal
- Due to the high internal recirculation rate in a CDS/FF system a noticeable amount of CO₂ is picked up by the lime
 - Lime consumption in CDS/FF systems will be higher than SDA/FF systems, especially at high removals
- Power consumption between SDA/FF and CDS/FF are approximately the same
 - SDA/FF power consumption is primarily the atomization power
 - CDS/FF power consumption is primarily due to the ID/booster fan power consumption
- The SDA/FF system has a slight advantage in utilities consumption

Waste Production

- Waste produced by CDS/FF systems is slightly more than wastes from SDA/FF systems due to CO₂ pickup by hydrated lime in the CDS
- The high pH in both SDA/FF and CDS/FF wastes helps immobilize mercury and other metals captured in the fabric filter.
- Wastes from both dry scrubber technologies will generally be disposed of in a landfill
- The Spray Dryer system has a slight advantage in wastes production

Selection of Dry Scrubber Technologies Summary

- The installed base of spray dryer/fabric filter systems is much larger than the present base of circulating dry scrubber/fabric filter systems
- CDS/FF systems have an advantage in SO₂ removal capability and fuel flexibility
- SDA/FF systems have an advantage in load flexibility, lime consumption, and an experience “base”
- Both systems have approximately the same water and power consumptions
- Overall selection between these 2 technologies will require an analysis guided by Utility priorities